

NANYANG PRIMARY SCHOOL
PRELIMINARY EXAMINATION
2011

PRIMARY 6
MATHEMATICS
PAPER 1

DURATION: 50 MINUTES

Booklet A	/ 20
Booklet B	/ 20

Paper 1 Total: / 40

Name: _____ ()

Class: Primary 6 ()

Date: 24 August 2011

Parent's Signature: _____

DO NOT OPEN THIS BOOKLET UNTIL YOU ARE TOLD TO DO SO.

FOLLOW ALL INSTRUCTIONS CAREFULLY.

ANSWER ALL QUESTIONS.

YOU ARE NOT ALLOWED TO USE A CALCULATOR.

PAPER 1 (BOOKLET A)

Questions 1 to 10 carry 1 mark each. Questions 11 to 15 carry 2 marks each. For each question, four options are given. One of them is the correct answer. Make your choice (1, 2, 3 or 4). Shade the oval (1, 2, 3 or 4) on the Optical Answer Sheet.

(20 marks)

- 1 Which one of the following pairs of numbers is smaller than 6405 but greater than 6356?

(1) 6392, 6450

(2) 6365, 6409

(3) 6361, 6400

(4) 6355, 6404

- 2 What is the missing number in the box?

$$430 - 130 = 40 + 56 + \square$$

(1) 204

(2) 214

(3) 296

(4) 396

3 Which one of the following numbers has the same number of factors as 30?

(1) 15

(2) 21

(3) 24

(4) 32

4 In 864.935, what is the value of the digit 9?

(1) 90 tens

(2) 90 tenths

(3) 90 hundredths

(4) 90 thousandths

5 What is the value of 320.65×9 ?

(1) 2785.45

(2) 2884.25

(3) 2885.85

(4) 2925.85

- 6 The figure on the right shows a cuboid with a square base. The volume of the cuboid is 200 cm^3 and its height is 8 cm . Find the length of the cuboid.

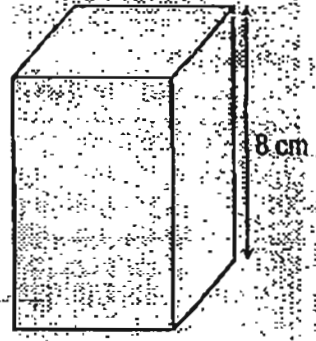

- (1) 5 cm
- (2) 6.25 cm
- (3) 25 cm
- (4) 1600 cm

- 7 In the figure below, AB and CD are straight lines. Find $\angle x$.

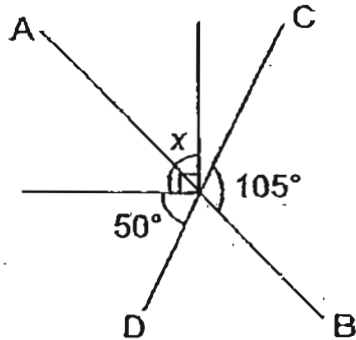

- (1) 10°
- (2) 20°
- (3) 35°
- (4) 45°

- 8 The figure below shows the net of a cube. Which 2 faces lie opposite each other?

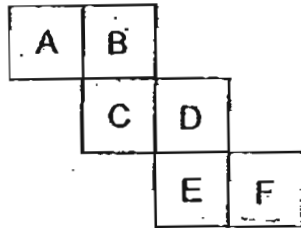

- (1) A and D
(2) B and F
(3) C and E
(4) D and F
- 9 The usual price of a watch is \$50. How much is the discount?

Brilliant Watch Shop

SALE !!

20% Discount



- (1) \$10
(2) \$20
(3) \$30
(4) \$40

10 What is the ratio of n cents to $\$n$?

- (1) 1 : 1
- (2) 1 : 100
- (3) 1 : n
- (4) n : 100

11 Sally was facing south at the beginning of a game.
Her classmates gave her some instructions to follow.

Judy said, "Make a $\frac{3}{4}$ -turn clockwise."

Then Annie said, "Turn 135° anticlockwise."

After making the 2 turns, which direction would Sally be facing?

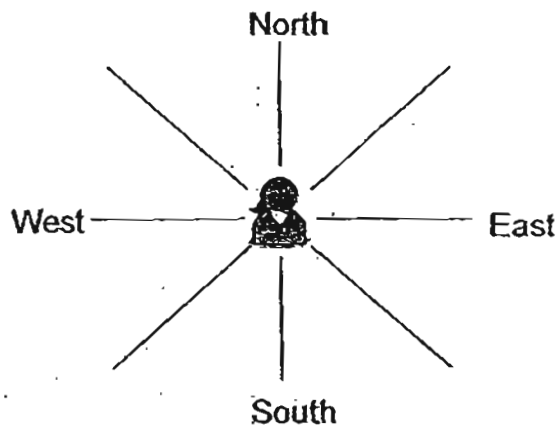

- (1) Northeast
- (2) Northwest
- (3) Southeast
- (4) Southwest

12 The ratio of the 3 sides of a right-angled triangle is 3 : 4 : 5. If the area of the triangle is 150 cm^2 , what is its perimeter?

- (1) 12 cm
- (2) 60 cm
- (3) 150 cm
- (4) 300 cm

13 Given that $\frac{2}{3}$ of Y is $\frac{3}{5}$ of X, what is the ratio of Y : X?

- (1) 3 : 2
- (2) 5 : 3
- (3) 9 : 10
- (4) 10 : 9

- 14 The pie chart shows how Mr Tan divided the cash prize which he won in a lucky draw. His daughter received $\frac{1}{3}$ of the amount that his wife received. His son received \$240. How much did his wife receive?

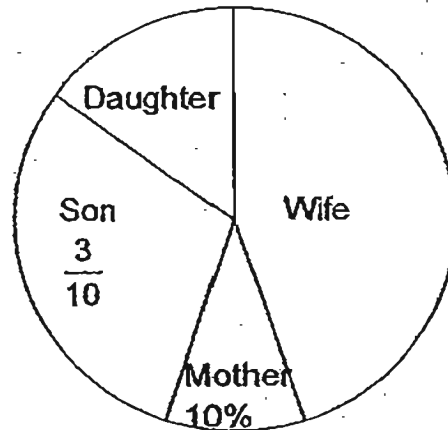

- (1) \$120
- (2) \$320
- (3) \$360
- (4) \$480

- 15 A solid made up of unit cubes is viewed from three different directions (Top, Front and Right) as shown in the figure below.

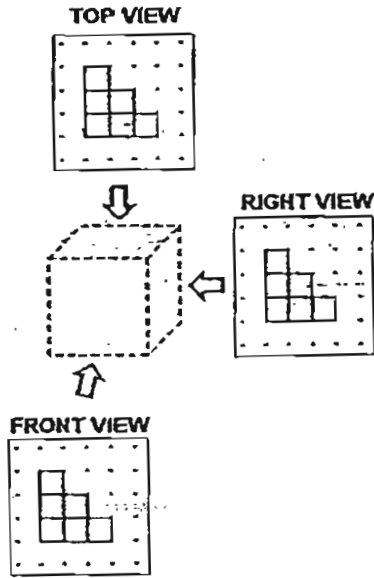

Which one of the following options could not be the possible arrangement of the cubes?

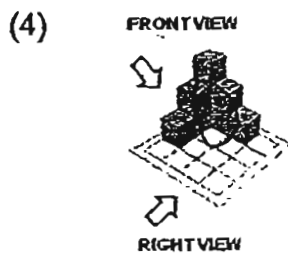
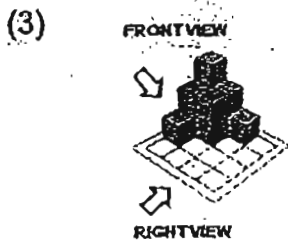
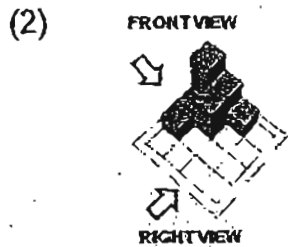
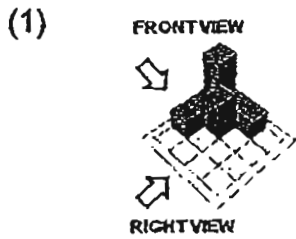

Name: _____ () Class: Pr 6 ()

P6 PRELIMINARY EXAMINATIONS 2011

PAPER 1 (BOOKLET B)

Questions 16 to 25 carry 1 mark each. Write your answers in the spaces provided. For questions which require units, give your answers in the units stated.

(10 marks)

16 Divide 8364 by 9. What is the remainder?

Ans: _____

17 What is the value of the missing fraction in the box? Leave your answer in its simplest form.

$$3\frac{1}{6} + \boxed{} = 4\frac{5}{6} - 1\frac{1}{2}$$

Ans: _____

18 Find the product of $3\frac{7}{12}$ and 4. Leave your answer in its simplest form.

Ans: _____

- 19 The mass of a sack of rice, when rounded off to the nearest hundredth is 36.45 kg. What is the smallest possible mass of the sack of rice?

Ans: _____ kg

- 20 John reached home at 02 05 after travelling for 10.5 hours. What time did he start travelling? Express your answer in 24-hour clock.

Ans: _____

- 21 Express 20.4 cm in metres.

Ans: _____ m

- 22 In the figure below, ABCD is a trapezium. Given that $\angle DCB = 130^\circ$ and $\angle DBA = 35^\circ$, find $\angle CBD$.

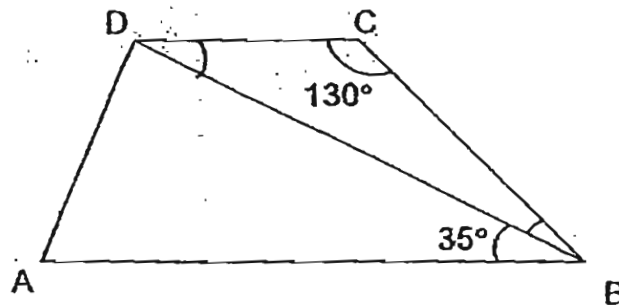

Ans: _____ °

23 Which one of the following words has only one line of symmetry?

AXE DOE COP DAD

Ans: _____

24 Mrs Tan needs to mix 3 litres of apple juice with 5 litres of orange juice to get the mixed juice she wants. How much apple juice does she need when she uses 9 litres of orange juice?

Ans: _____ litres

25 Mr Lim cycles 5 km in 25 minutes. Find his average speed in m/min.

Ans: _____ m/min

Questions 26 to 30 carry 2 marks each. Show your working clearly in the space provided for each question and write your answers in the spaces provided. For questions which require units, give your answers in the units stated.

(10 marks)

26 Find the value of $22 \times (43 - 38) + 48 \div 8 - 9$:

Ans: _____

27 A bag of pepper weighed $8\frac{5}{6}$ kg. The shopkeeper repacked all of it into smaller packets of either 2 kg or $\frac{1}{12}$ kg each. There were four 2-kg packets. How many more $\frac{1}{12}$ -kg packets than 2-kg packets did he have?

Ans: _____

- 28 The table below shows how John, David and Mary spent their pocket money last week.

Name	Transport	Books	Food	Toys	Total
John	\$50	\$30	\$45	\$20	\$145
David	?	\$40	\$60	\$30	?
Mary	\$40	\$40	\$95	\$0	\$175

The amount of money David spent on transport was 25% of the total amount of money the 3 children spent on food. How much pocket money did David spend?

Ans: \$ _____

- 29 In the figures below, 4 identical rectangular strips of paper were arranged into two different patterns whereby the 2 horizontal strips were placed over the 2 vertical strips.

In Figure A, the 2 horizontal strips formed a rectangle of breadth 6 cm. In Figure B, the area of the empty space outlined by the 4 strips was 100 cm^2 . Find the length of 1 rectangular strip of paper.

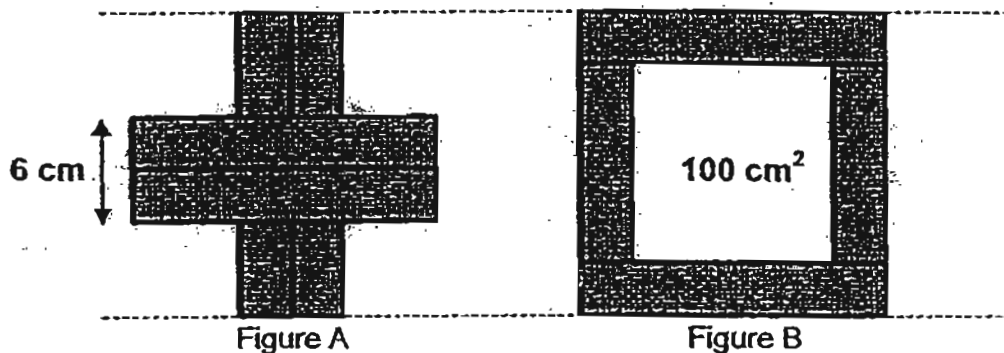

Ans: _____ cm

30 The figure below is made from some pieces of

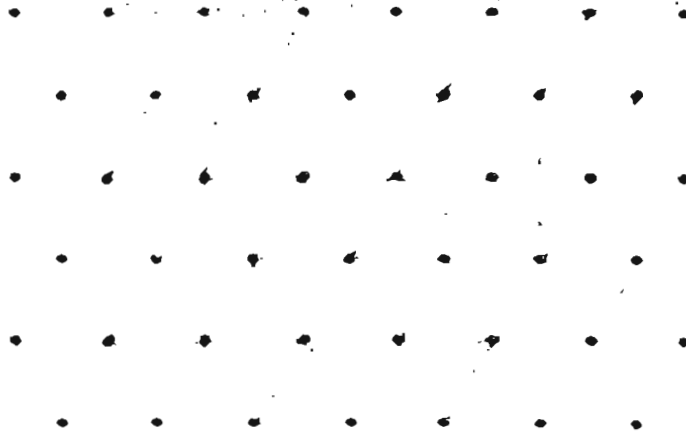
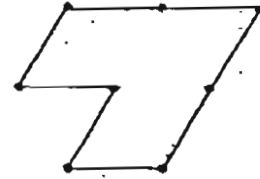

Draw appropriate lines in the figure above to show all the unit shapes that formed the tessellation.



**NANYANG PRIMARY SCHOOL
PRELIMINARY EXAMINATION
2011**

**PRIMARY 6
MATHEMATICS**

PAPER 2

DURATION: 1 HOUR 40 MINUTES

Paper 2 Total	/ 60
----------------------	-------------

GRAND TOTAL	/ 100
--------------------	--------------

Name: _____ ()

Class: Primary 6 ()

Date: 24 August 2011

Parent's Signature: _____

DO NOT OPEN THIS BOOKLET UNTIL YOU ARE TOLD TO DO SO.

FOLLOW ALL INSTRUCTIONS CAREFULLY.

ANSWER ALL QUESTIONS.

YOU ARE ALLOWED TO USE A CALCULATOR.

PAPER 2

Questions 1 to 5 carry 2 marks each. Show your working clearly in the space provided for each question and write your answers in the spaces provided. For questions which require units, give your answers in the units stated.

(10 marks)

- 1 Mr Tan's bookshelf has enough space for either $15x$ hardcover books or 20 paperbacks. If there are already 18 hardcover books and 4 paperbacks, how many more hardcover books can be placed on the bookshelf? Express your answer in terms of x .

Ans: _____

- 2 The figure below shows the net of a cuboid made of 4 identical rectangles and 2 identical squares. Find the volume of the cuboid.

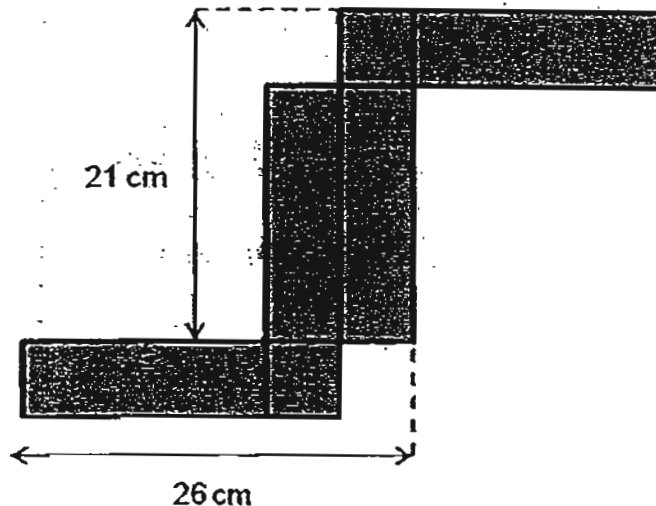

Ans: _____ cm^3

- 3 Peter's Mathematics score for the mid-year examination was 76. His Mathematics score for the year-end examination was 95. Find the percentage increase in his Mathematics score.

Ans: _____ %

- 4 The bar graph below shows the Science results of a group of pupils.

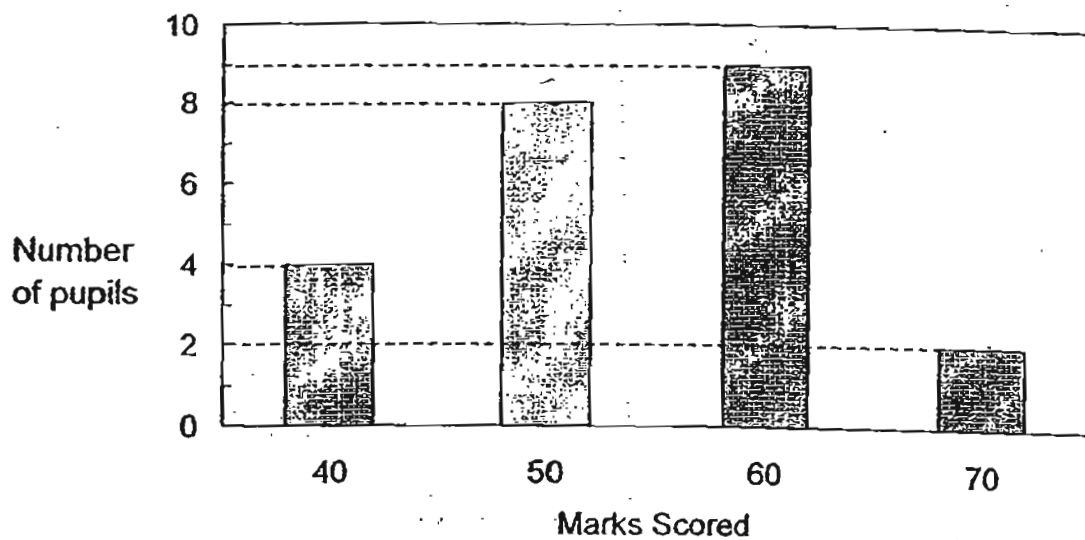

Find the average marks obtained by pupils who scored 40 marks, 50 marks and 70 marks.

Ans: _____

- 5 The figure below shows a right-angled triangle ABC.

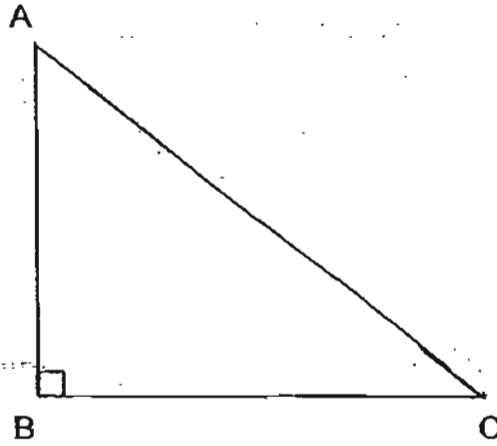

In the figure above, draw two lines, AD and CD, such that $AD \parallel BC$ and $\angle ACD = 60^\circ$.

For questions 6 to 18, show your working clearly in the space provided for each question and write your answers in the spaces provided.

The number of marks available is shown in brackets [] at the end of each question or part-question.

(50 marks)

-
- 6 The cost of 3 apples is the same as that of 2 oranges. The total cost of 4 apples and 3 oranges is \$3.40. Mrs Tan bought 7 apples and 5 oranges. How much did she pay for apples and oranges altogether?

Ans: _____ [3]

-
- 7 Andy, Ben and Carl went for dinner and paid a total of \$935 for the meal. Andy paid 25% of what Ben and Carl had paid. Ben paid 20% more than what Andy and Carl had paid. How much did Carl pay for his share of the dinner?

Ans: _____ [3]

- 8 The square ABCD was cut into 6 parts using 5 straight lines. The length of the square is 15 cm. Given that the ratio of AE : EG is 1 : 1, the ratio of BF : FG : GD is 2 : 1 : 3 and the ratio of BH : HC is 1 : 3. Find the total area of the shaded parts.

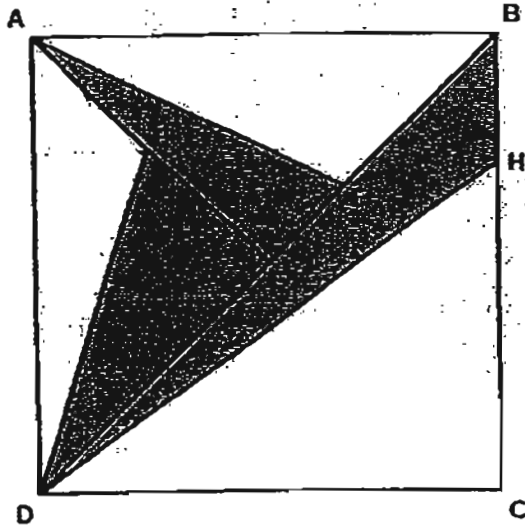

Ans: _____ [3]

- 9 Mrs Tan purchased some shoes at \$294.52 from USA. She engaged a shipping company to ship them back to Singapore. The cost of shipping is as follows:

USA Shipping Charge	
Base Charge	\$13.40
Weight Charge	\$7.45/kg
Fuel Surcharge	\$1.90/kg

Given that the weight of her purchases was 10.8 kg, how much did she pay for the shoes in all?

Ans: _____ [3]

- 10 Ali and Ben started jogging from Park X to Park Y at the same time. Ali jogged at an average speed of 7.5 km/h while Ben jogged at an average speed of 4.5 km/h. After jogging for 1.2 h, Ali decided to turn back and jog towards Ben. Ali met Ben at Point Z which was halfway between Park X and Park Y. Ali and Ben then continued their jog together towards Park Y at an average speed of 4.5 km/h. What was the distance between Park X and Park Y?



Ans: _____ [3]

- 11 Bob plans to cover a wall of length 6 m and height 3.2 m with either Design A or Design B as shown below. Both designs are squares of length 40 cm and identical semi-circular arcs are used to outline the design within each square.

Bob will like to paint the shaded area of the design which he selects for the wall. To save on paint, Bob will like to select the design that has the lesser shaded area.

How much more area does Bob have to paint if he accidentally selects the design that has the greater shaded area instead? (Take $\pi = 3.14$)

40 cm

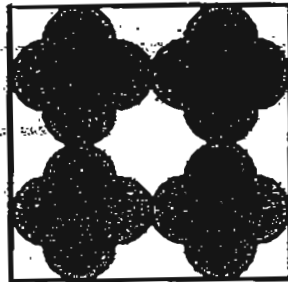

Design A

40 cm

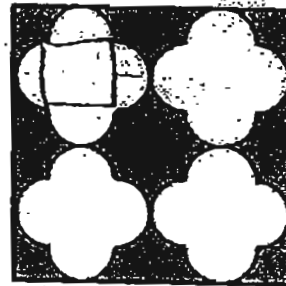

Design B

Ans: _____ [4]

- 12 The graph below shows the number of television sets sold by Shop A and Shop B from April to August.

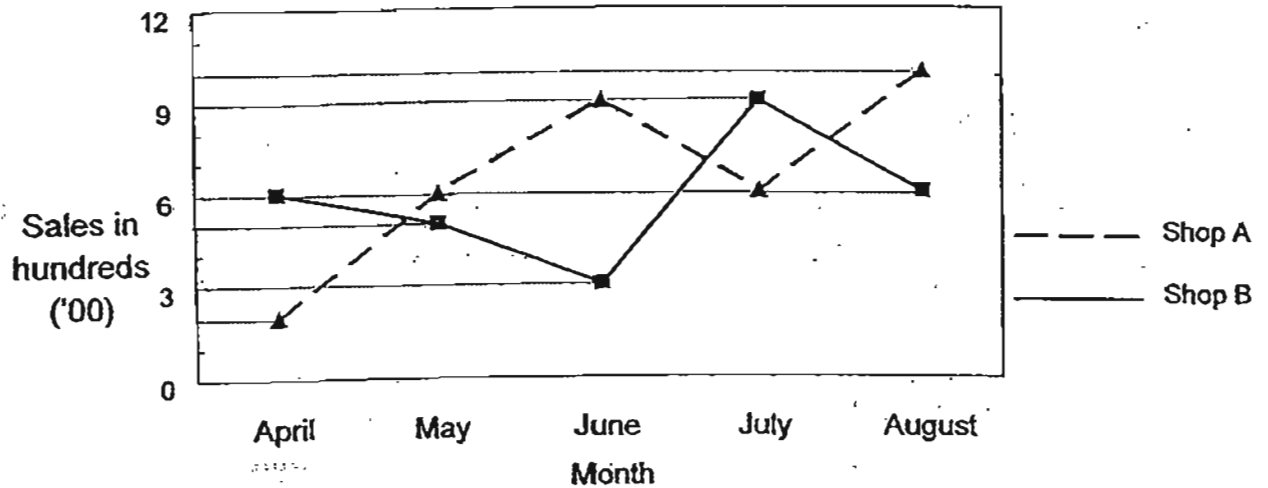

- (a) Use the information given in the graph to complete the table given below. [1]

Month	Shop A	Shop B
April	200	
May	600	500
June		
July	600	
August		600

- (b) What was the total number of television sets sold by Shop A from April to July?
- (c) Shop A sold each television set at a fixed price of \$1200. In September, a sum of \$418 800 was collected from the sales of television sets. How many more television sets were sold in July than September?

Ans: (b) _____ [1]

(c) _____ [2]

13 In the figure below, ABCD is a rectangle and KMN is a triangle. Given that $\angle A Q K = 114^\circ$, $\angle Q L M = 110^\circ$, $\angle P M N = 24^\circ$ and JKLM is a straight line, find

(a) $\angle x$, and

(b) $\angle y$.

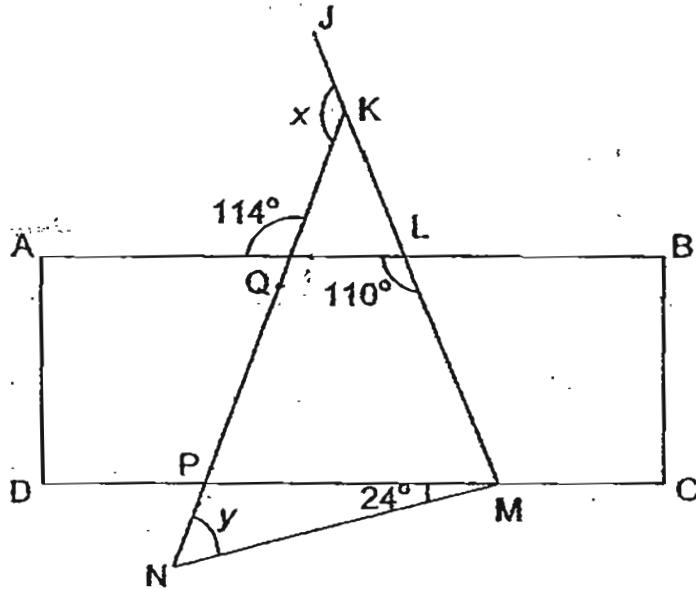

Ans: (a) _____ [2]

(b) _____ [2]

- 14 In the village of Happipeople, the villagers built their houses underground as shown in the figure below.
- Fill in the House Numbers of Basement Level 6 in the figure below.
 - Miss Sunshine stays in the house on the extreme right of Basement Level 10. What is her House Number?
 - Mr Beam stays at Basement Level 100. What is the smallest House Number on Mr Beam's level?

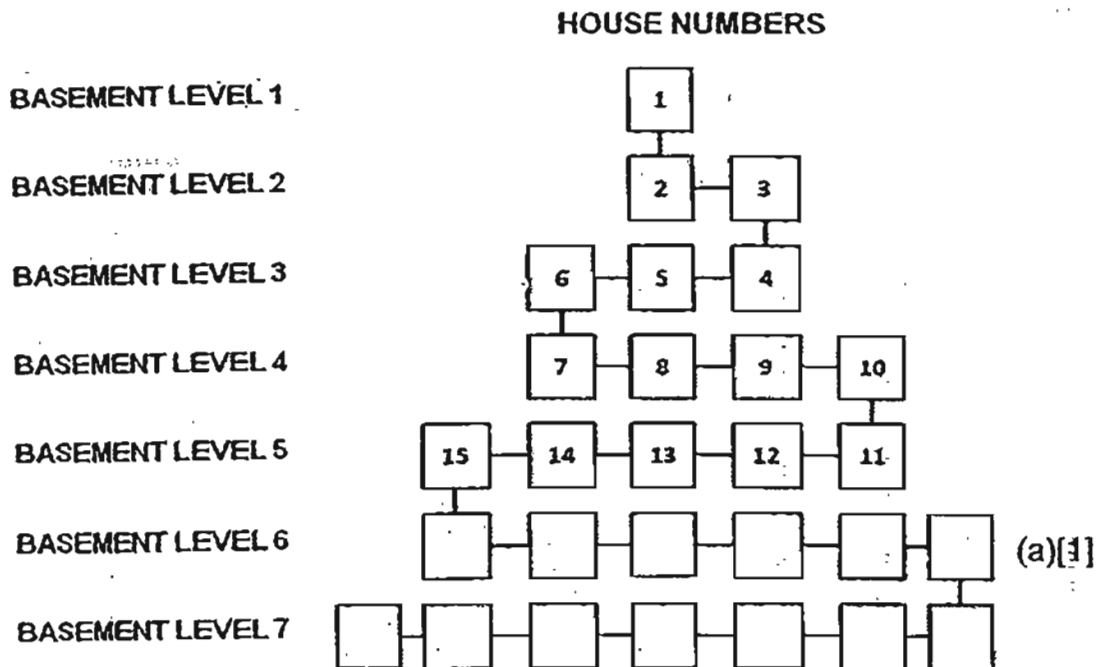

Ans: (b) _____ [1]

(c) _____ [2]

- 15 A rectangular tank measuring 3 m by 3 m by 1.5 m was $\frac{1}{3}$ filled with water. A tap was turned on to fill it up with water at a rate of 18 l/min. Every 2 minutes after the tap was turned on, 6 l of water was poured from a pail into the tank. How long did it take for the rectangular tank to be completely filled with water? Leave your answer as a mixed number in its simplest form.

Ans: _____ [4]

- 16 In a confectionery, $\frac{3}{10}$ of the cupcakes baked were strawberry cupcakes, $\frac{1}{2}$ of them were chocolate cupcakes and the rest were grape cupcakes. $\frac{2}{7}$ of the strawberry cupcakes were sold. This was $\frac{1}{2}$ of the number of chocolate cupcakes sold. The number of grape cupcakes sold was $\frac{1}{4}$ the total number sold in the other two flavours. Given that there were 190 cupcakes left, how many cupcakes were there at first?

Ans: _____ [5]

- 17 Packet A, Packet B and Packet C each contained some salt. At first, there were 200 g more salt in Packet A than Packet B. Packet C had $\frac{3}{4}$ of the amount of salt in Packet A. After $\frac{1}{8}$ of the amount of salt in Packet A was transferred to Packet B, there was 82.15 g of salt in Packet B. How many percent less salt were there in Packet C than Packet A at first? ~~Give your answer correct to 1 decimal place.~~

Ans: _____ [5]

18) In a cinema, the ratio of the number of girls to the number of boys was 3 : 2. The ratio of the number of women to the number of boys was 5 : 4. The ratio of the number of girls to the number of men was 2 : 5. During the movie, 6 women and 27 men left the cinema. The ratio of the number of women to the number of men then became 1 : 2.

- (a) Express the number of women as a fraction of the number of men at first. Leave your answer in its simplest form.
- (b) How many children were there in the cinema?

Ans: (a) _____ [2]

(b) _____ [2]

END OF PAPER

Answer Ke

EXAM PAPER 2011

SCHOOL : NANYANG
SUBJECT : PRIMARY 6 MATHEMATICS

TERM : PRELIMINARY

Q1	Q2	Q3	Q4	Q5	Q6	Q7	Q8	Q9	Q10	Q11	Q12	Q13	Q14	Q15
3	1	3	3	3	1	3	1	1	2	2	2	3	3	4

- 16) 3 17) $1/6$ 18) $14\frac{1}{3}$ 19) 36.445kg 20) 1535
- 21) 0.204m 22) 15° 23) DOE 24) 5.4L 25) 200m/min
- 26) 107 27) 6 28) \$180 29) 16cm 30)

Paper 2

1) $20 \rightarrow 15x$

$4 \rightarrow 3x$

$15x - 3x - 18 = (12x - 18)$

2) $26 - 21 = 5$

$26 - 5 - 5 = 16$

$16 \times 5 \times 5 = 400\text{cm}^3$

3) $95 - 76 = 19$

$19/76 \times 100\% = 25\%$

4) $4 \times 40 + 8 \times 50 + 2 \times 70 = 700$

$700 \div (4+8+2) = 50$

5)

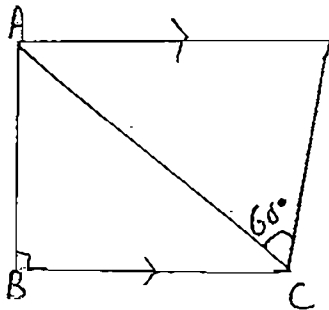

6) $\$3.40 \times 3 = \10.20

$\$10.20 \div 17 = \0.60

$\$0.60 \times 2 = \1.20

$\$1.20 \div 3 = \0.40

$\$0.40 \times 7 = \2.80

$\$0.60 \times 5 = \3

$\$3 + \$2.80 = \$5.80$

7) $125\% \rightarrow \$935$

$25\% \rightarrow \$935 \div 5 = \187 (A)

$120\% + 100\% \rightarrow \935

$220\% \rightarrow \$935$

$120\% \rightarrow \$510 \text{ (B)}$

$\$935 - \$510 = \$238$

8) $\triangle BCD = \frac{1}{2}$

$\triangle BDH = \frac{1}{2} \times \frac{1}{4} = \frac{1}{8}$

$\triangle AGB = \frac{1}{4}$

$\triangle AGF = \frac{1}{4} \times \frac{1}{3} = \frac{1}{12}$

$\triangle AGD = \frac{1}{4}$

$\triangle DGE = \frac{1}{4} \times \frac{1}{2} = \frac{1}{8}$

$\frac{1}{8} + \frac{1}{12} + \frac{1}{8} = \frac{1}{3}$

$\frac{1}{3} \times 15 \times 15 = 75\text{cm}^2$

$$\begin{aligned}
 9) & \$7.45 + \$1.90 = \$9.35 \\
 & \$9.35 \times \$10.8 = \$100.98 \\
 & \$100.98 + \$13.40 + \$294.52 \\
 & = \$408.90
 \end{aligned}$$

$$\begin{aligned}
 10) & \text{Ali's} \rightarrow 7.5 \times 1.2 = 9 \\
 & \text{Ben's} \rightarrow 1.2 \times 4.5 = 5.4 \\
 & 9 - 5.4 = 3.6 \\
 & \text{In 1h} \rightarrow 7.5 + 4.5 = 12 \\
 & 3.6 \div 12 = 0.3 \\
 & = 3/10 \text{ (time taken to meet)} \\
 & 3/10 \times 4.5 = 1.35 \\
 & 1.35 + 4.5 = 6.75 \\
 & 6.75 \times 2 = 13\frac{1}{2} \text{ km}
 \end{aligned}$$

$$\begin{aligned}
 11) & 6\text{m} = 600\text{cm} \\
 & 600 \div 40 = 15 \\
 & 3.2\text{m} = 320\text{cm} \\
 & 320 \div 40 = 8 \\
 & 8 \times 15 = 120 \\
 & 1 \text{ diameter} \rightarrow 40 \div 4 = 10 \\
 & \text{Area of 1 design} \rightarrow 40 \times 40 = 1600 \\
 & \text{Shaded area of 1 flower} \rightarrow 2\odot + 1\square \\
 & = 2 \times 3.14 \times 5 \times 5 + 10 \times 10 = 257 \\
 & 4 \text{ flowers} \rightarrow 257 \times 4 = 1028 \text{ (diagram A)} \\
 & \text{Design B} = 1600 - 1028 = 572 \\
 & \text{Difference} = 1028 - 572 = 456 \\
 & 456 \times 120 = 54720\text{cm}^2
 \end{aligned}$$

$$\begin{aligned}
 12) & \text{a) April} = 600 \\
 & \text{June} = 900, 300 \\
 & \text{July} = 900 \\
 & \text{August} = 1000 \\
 & \text{b) } 200 + 600 + 600 + 900 = 2300 \\
 & \text{c) } \$418800 \div \$1200 = 349 \\
 & 600 - 349 = 251
 \end{aligned}$$

$$\begin{aligned}
 13) & \text{a) } \angle QLK \rightarrow 180^\circ - 110^\circ = 70^\circ \\
 & \angle KQL \rightarrow 180^\circ - 114^\circ = 66^\circ \\
 & \angle X \rightarrow 66^\circ + 70^\circ = 136^\circ \\
 & \text{b) } \angle Y \rightarrow 180^\circ - 114^\circ - 24^\circ = 42^\circ
 \end{aligned}$$

$$\begin{aligned}
 14) & \text{a) } 28 + 8 = 36 \\
 & 36 + 9 = 45 \\
 & 45 + 10 = 55 \\
 & \text{b) } 100 \div 2 = 50 \\
 & 99 \times 50 = 4950 \\
 & 4950 + 1 = 4951
 \end{aligned}$$

$$\begin{aligned}
 15) & 1\text{m}^3 = 1000000\text{cm}^3 = 1000\text{L} \\
 & 1 - 1/3 = 2/3 \\
 & 2/3 \times 300 \times 300 \times 150 = 9000000 \\
 & 9000000\text{cm}^3 = 9000\text{L} \\
 & \text{Tap} \rightarrow 18\text{L} \times 2 = 36\text{L} \\
 & \text{Pail} \rightarrow 6\text{L} \\
 & 36 + 6 = 42 \\
 & 9000 \div 42 = 214\text{R}12\text{L} \\
 & 1\text{min} \rightarrow 18\text{L} \\
 & 12/18\text{min} \rightarrow 12\text{L} = 2/3\text{min} \\
 & 214 \times 2 + 2/3 = 428\frac{2}{3}\text{min}
 \end{aligned}$$

$$16) 280$$

$$17) 25\%$$

$$18) \text{a) } 1/3$$

$$\text{b) } 30$$

working solution
is attached behind

- 16 In a confectionery, $\frac{3}{10}$ of the cupcakes baked were strawberry cupcakes, $\frac{1}{2}$ of them were chocolate cupcakes and the rest were grape cupcakes. $\frac{2}{7}$ of the strawberry cupcakes were sold. This was $\frac{1}{2}$ of the number of chocolate cupcakes sold. The number of grape cupcakes sold was $\frac{1}{4}$ the total number sold in the other two flavours. Given that there were 190 cupcakes left, how many cupcakes were there at first?

<u>Before</u>	<u>left</u>
$S \rightarrow \frac{3}{10}$	$S \rightarrow \frac{3}{10} - \frac{3}{35}$
$C \rightarrow \frac{1}{2} = \frac{5}{10}$	$= \frac{21}{70} - \frac{6}{70}$
$G \rightarrow 1 - \frac{3}{10} - \frac{5}{10}$	$= \frac{15}{70} = \frac{30}{140}$
$= \frac{2}{10}$	$C \rightarrow \frac{5}{10} - \frac{6}{35}$
<u>Sold</u>	$= \frac{35}{70} - \frac{12}{70}$
$S \rightarrow \frac{3}{10} \times \frac{2}{7}$	$= \frac{23}{70} = \frac{46}{140}$
$= \frac{3}{35}$	$G \rightarrow \frac{2}{10} - \frac{9}{140}$
$C \rightarrow \frac{2}{10} \times \frac{3}{35}$	$= \frac{28}{140} - \frac{9}{140}$
$= \frac{6}{35}$	$= \frac{19}{140}$
$S+C \rightarrow \frac{3}{35} + \frac{6}{35}$	$\frac{30}{140} + \frac{46}{140} + \frac{19}{140} = \frac{95}{140}$
$= \frac{9}{35}$	$\frac{95}{140} \rightarrow 190$
$G \rightarrow \frac{1}{4} \times \frac{9}{35}$	$\frac{1}{140} \rightarrow 2$
$= \frac{9}{140}$	$\frac{140}{140} \rightarrow 280$

There were 280 cupcakes at first.

Ans: 280 cupcakes [5]

7)

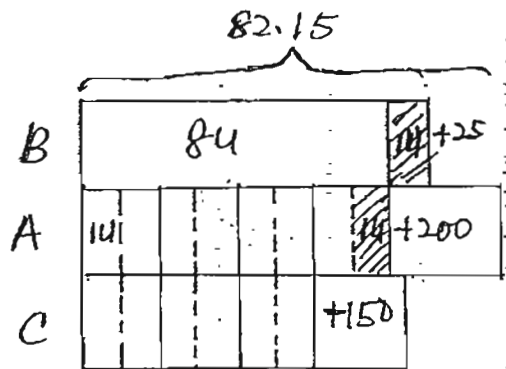

$$84 + 11 + 25 \rightarrow 82.15$$

$$94 + 25 \rightarrow 82.15$$

$$94 \rightarrow 82.15 - 25$$

$$94 \rightarrow 57.15$$

$$11 \rightarrow 6.35$$

$$\begin{aligned} A &\rightarrow 84 + 200 \\ &= (8 \times 6.35) + 200 \\ &= 50.8 + 200 \\ &= 250.8 \end{aligned}$$

$$\begin{aligned} C &\rightarrow 64 + 150 \\ &= (6 \times 6.35) + 150 \\ &= 38.1 + 150 \\ &= 188.1 \end{aligned}$$

$$\text{Diff A and C} \rightarrow \frac{250.8 - 188.1}{62.7}$$

$$\frac{62.7}{250.8} = \frac{1}{4}$$

$$\frac{1}{4} \times 100\% = 25\%$$

There was 25% less salt in Packet C than A at first.

18)

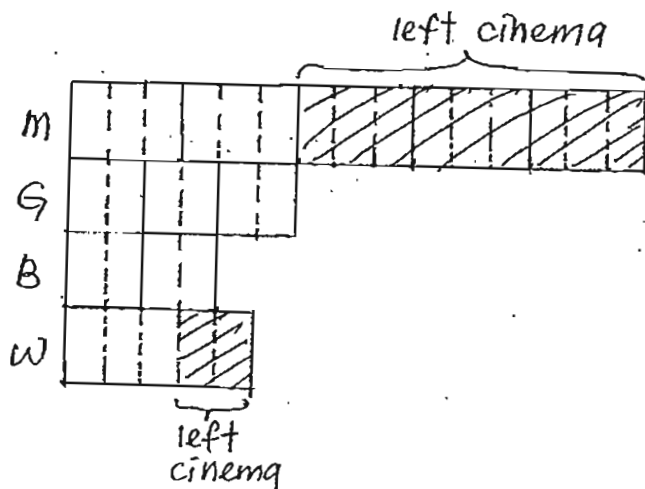

a) Woman 5U
Man 15U

$$\frac{5}{15} = \frac{1}{3}$$

b) Total man and women left cinema

$$11U \rightarrow 33$$

$$1U \rightarrow 33 \div 11$$

$$= 3$$

Total children Boys and girls

$$10U \rightarrow 10 \times 3$$

$$= 30$$

There are 30 children at the cinema.